

SANFU

3-4 TON

DIESEL FORKLIFT TRUCK SERIES



Features	1	Manufacturer		Power shift T/M	FD30T	FD35T	FD40T	
	2	Model		Manual shift T/M	FD30C	FD35C	FD40C	
	3	Load capacity		kg	3000	3500	4000	
	4	Load center		mm	500	500	500	
	5	Power unit			Diesel	Diesel	Diesel	
	6	Operator type			Driver/seat	Driver/seat	Driver/seat	
	7	Tire type			Pneumatic	Pneumatic	Pneumatic	
	8	Wheel	Front/rear		2/2	2/2	2/2	
Dimension	9	Max. lifting height		mm	3000	3000	3000	
	10	Free lift		mm	150	150	150	
	11	Fork size	L*W*T	mm	1070*125*45	1070*125*50	1070*150*50	
	12	Tilt range	Mast forward/backward	deg	6/12	6/12	6/12	
	13	Overall length(without fork)		mm	2705	2760	2870	
	14	Total width		mm	1225	1285	1365	
	15	Mast height (fork lowering)		mm	2075	2075	2150	
	16	Overall height fork raised	With backrest	mm	4250	4250	4250	
	17	Height to head guard		mm	2140	2140	2140	
	18	Turning radius(outside)		mm	2445	2495	2530	
	19	Front face of fork to front axle		mm	480	485	485	
	20	Min. right angle stacking aisle	without load length&clearance	mm	2925	2975	2940	
Performance	21	Speed	Max Travelling full/no load	km/h	18/19.5	18/19.5	16.5/18	
	22		Lifting full/no load	mm/s	450/500	450/500	380/480	
	23		Lowering full/no load	mm/s	450/450	450/420	450/420	
	24	Max.drawbar pull	Power shift T/M full/no load	kg	1500/1000	2200/1000	2200/1000	
			Manual shift T/M full/no load	kg	1550/1000	2200/1000	2200/1000	
	25	Gradeability at 1.6km/h	Power shift T/M full/no load	%	18/20	18/20	18/20	
	Manual shift T/M full/no load		%	18/20	18/20	18/20		
Weight	26	Truck weight		kg	4380	4780	5050	
	27	Weight distribution	Full load front/rear	kg	6490/890	7380/900	7890/1140	
	28		No load front/rear	kg	1670/2700	1820/2960	1810/3240	
Frame	29	Tires	Number	front/rear	2/2	2/2	2/2	
	30		front axle	28x9-15-12PR	28x9-15-12PR	250-15-16PR		
	31		Model	rear axle	6.50-10-10PR	6.50-10-10PR	6.50-10-10PR	
	32	Wheelbase		mm	1700	1700	1800	
	33	Tread	Front/rear	mm	1000/970	1060/970	1120/970	
	34	Ground clearance	At lowest point(mast)	mm	120	120	120	
			Frame	mm	135	135	135	
	35	Brake	Service brake			Hydraulic-foot pedal	Hydraulic-foot pedal	Hydraulic-foot pedal
		Parking brake			Mechanical-hand lever	Mechanical-hand lever	Mechanical-hand lever	
Engine	36	Battery	Voltage/capacity	V/AH	12/80	12/80	12/80	
	37	Engine	Model		XINCHAI C495	XINCHAI C495	XINCHAI C495	
			Rated power	kw/rpm	45/2650	45/2650	45/2650	
			Rated torque	N.m/rpm	186/1800	186/1800	186/1800	
			Number of cylinders		4	4	4	
			Placement	L	3.168	3.168	3.168	
			Fuel tank capacity	L	70	70	70	
	38	Transmission	Speed forward/backward	Power shift T/M		1-1 power shift T/M	1-1 power shift T/M	1-1 power shift T/M
				Manual shift T/M		2-2 manual shift T/M	2-2 manual shift T/M	2-2 manual shift T/M
	39	Operating pressure	Hydraulic system pressure	kg/cm ²	180	180	180	

Notes :Besides the engine above, SANFU also have the Isuzu C240 and Deutz 498 engine, Yanmar 4TNE98 for choice.Performance data will be changed according to the different engines.

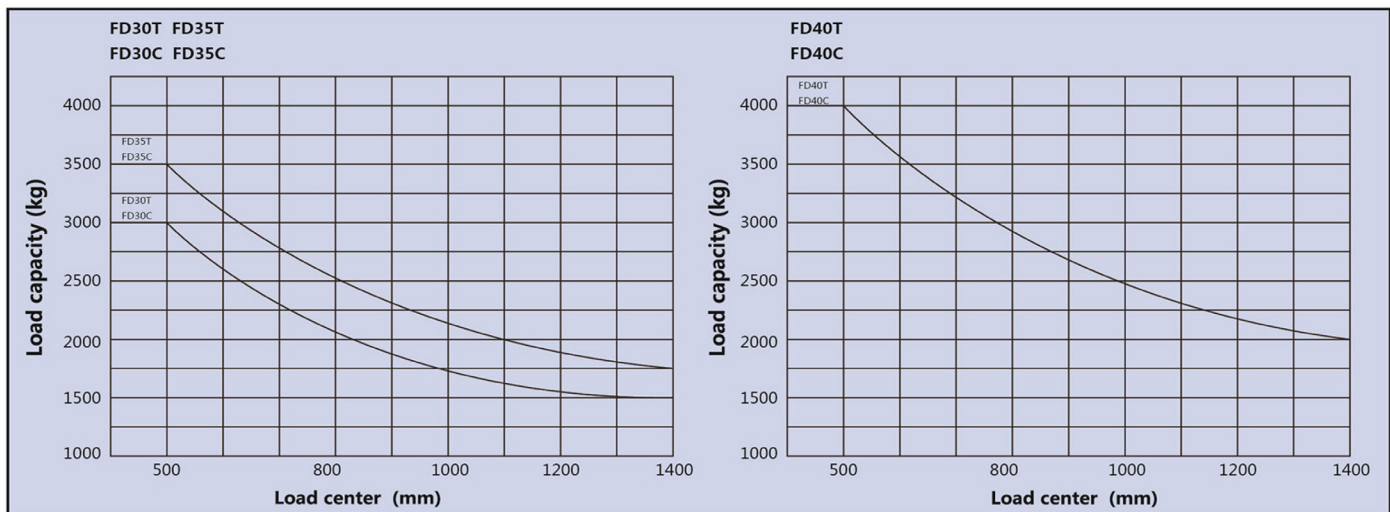

Notes:

Vertical axis represents load capacity; Horizontal axis shows load center, Load center are determined from front face of the fork. Capacity based on a 1000mm cube load configuration with the center of gravity at the true center of the cube, and standard fork. The load capacity will be reduced while the mast tilt forward or loading with long fork or lifting transformable width of goods. Getting the load capacities at the various load centers via the load curve.

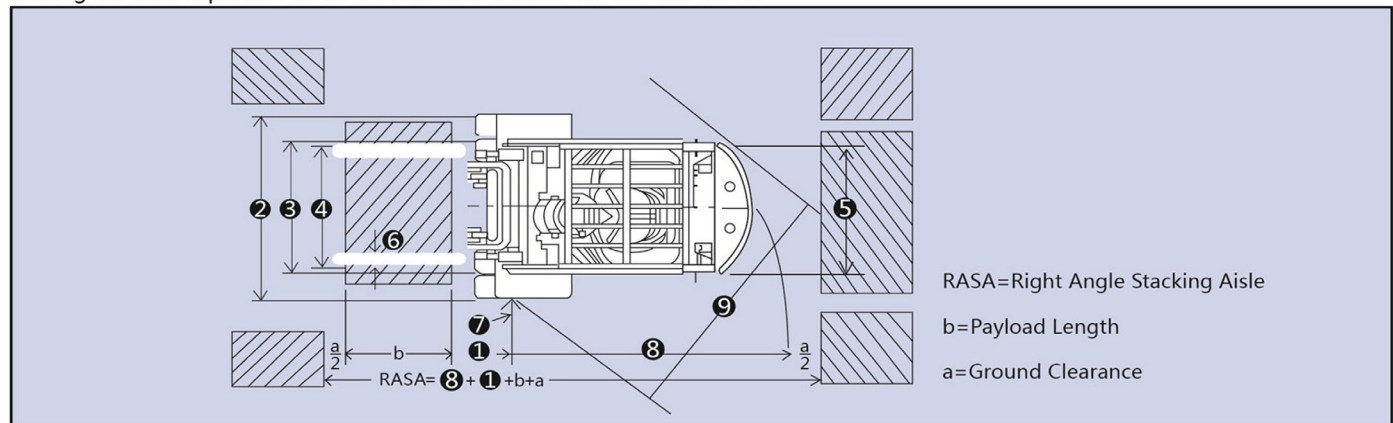

Specifications (front single tires)

Model	FD30C • FD30T	FD35C • FD35T	FD40C • FD40T
	(mm)	(mm)	(mm)
①Front Overhang	480	485	485
②Total Width	1225	1285	1365
③Front Track	1000	1060	1120
④Front Spread (outside)	250-1090	250-1190	250-1190
⑤Rear Track	970	970	970
⑥Fork Width	125	125	150
⑦Turning Radius (inside)	200	200	200
⑧Turning Radius (outside)	2445	2495	2530
⑨Right Angle Turning Aisle	2155	2205	2450

Standard equipments:

Wide view mast, Cyclone air cleaner, Load one-way valve, Preheat indicator, King Pin, Engine-start switch, Standard backrest, Long-life tires, Overhead guard, Oil and Water separator, Power steering, Adjustable steering column, Radiator water tank, Side roller, Standard carriage.

Oil temperature cooler, Headlamp and steering indicator lamp, Charge indicator lamp, Hour meter, Oil warning light of engine. Water temperature gauge, Fuel gauge, Reversing light, Electric horn, Neutral-safety switch, Rear mirror, Tools, Reversing buzzer, General seat.

Options:

Fire extinguisher, Cab, Heater unit, Rear work light, Solid tires, Fireproof silencer, Upper exhaust pipe, Tilt cylinder jacket, Rotating warning light, Pre-filtration air intake device.

Attachments:

Side shifter, Fork positioned, Carpet boom, Fork extension, Long fork, Flat clamp, Others.



- 1、Original Xinchai engine, high quality complaint with worldwide stage IIIA emission stanard, the powerful engine ensures SANFU forklift truck high handling performance
- 2、The standard LED lamps and warning lights make it safer, more energy efficient and create better working condition.
- 3、Ergonomics Adjustable seat : Designed according to the ergonomic principles, make the operation much comfortable and also relieves the fatigue caused by long time continuous operation.
- 4、New designed overhead guard protective device prevent the sudden accidents.
- 5、The full free 3-stage mast adopt German import channel with advanced welding technology , increase the stability of ascension, durability and the width of front mast view, reduce the height of the instrument stand, expand the visibility of pallet fork tip and goods. (Optional)
- 6、Bigger and non-slip step make the operating convenient and safe.
- 7、Security system: Equipped with OPS or ORS seat and brake switch to prevent incorrect operation and secure the driver and the forklifts from all sides. (Optional)
- 8、Install optional three-way catalytic device to lower the harmful emission beside of low emission engines; adopt sound-proof cotton to ease noise and high exhaust system as option to reduce dust. (Optional)

- Diesel Forklift Series (3-4 ton)
- LPG/Gasoline Forklift Series
- Electric Forklift Series

SANFU



Durabuilt Motors Inc.

Authorized Agent

Seller expresses Forklift manufacturer for the contract or his authorized agent